



APPLICATION & ASSEMBLY INSTRUCTION

XROSSLINK series Power connectors **IP65**

ROXTONE
world in connect

A. APPLICATION INSTRUCTION

APPLICATION:

XROSSLINK series is intended for use as an appliance coupler and interconnection coupler. It serves to supply power to an appliance and from an appliance to other equipment. To be installed by qualified person only.

Connector Appliance:

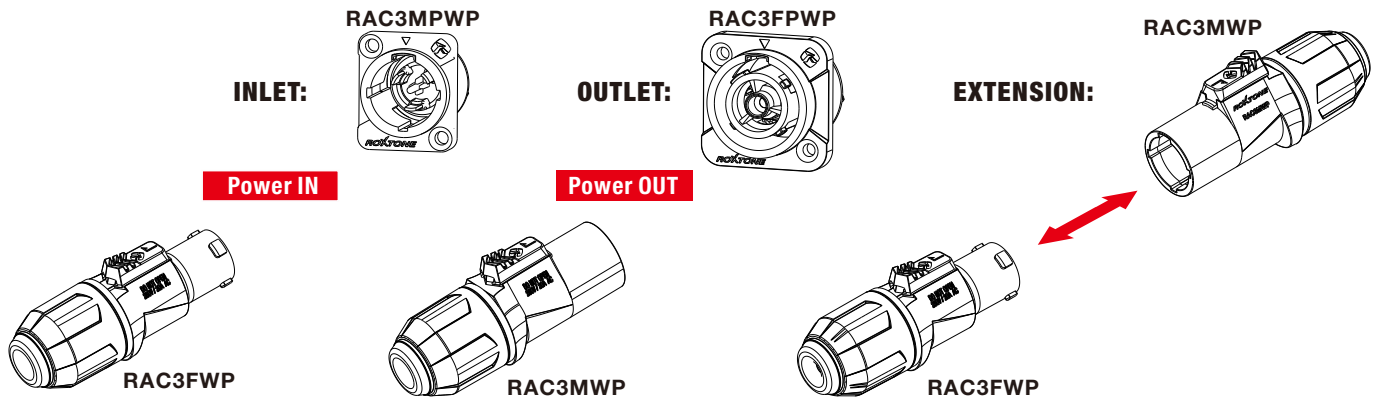

Technical Data

Rating:	250 V ac / 20 A
Strain Relief Clamp:	White Clamp
Cable O.D.:	6.0 - 12.0 mm

B. ASSEMBLY INSTRUCTION

STEP 1 Insert cable into the bushing and housing.

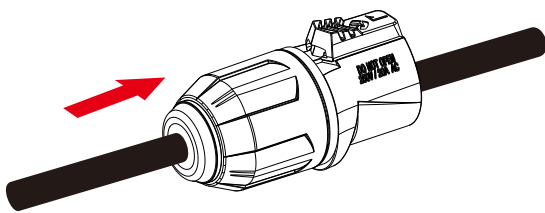

STEP 2 Separate the housing from the bushing (cable remain in bushing)

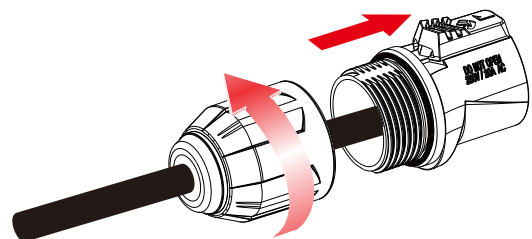

STEP 3 Place clamp over the cable.

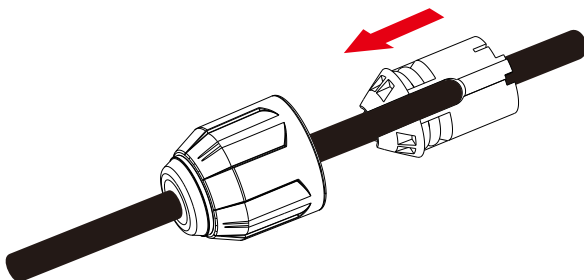

STEP 4 Prepare cable as shown.

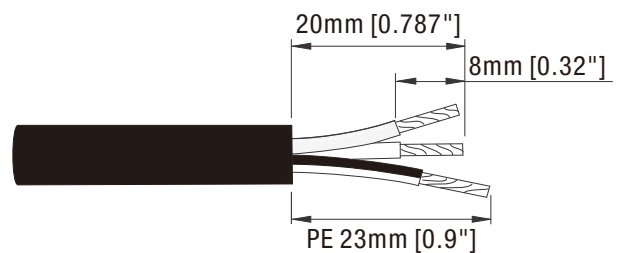



STEP 5 Slide cable into contact and clamp with screw.

 **Screw** Max. Torque Value 0.7 Nm

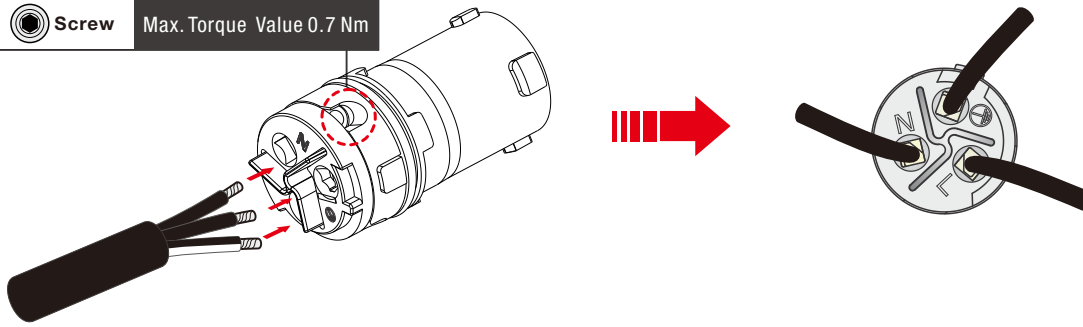

STEP 6 Slide clamp onto insert **1** and then both into housing **2**
 Important: Align the clamp by positioning the nose into keyway.

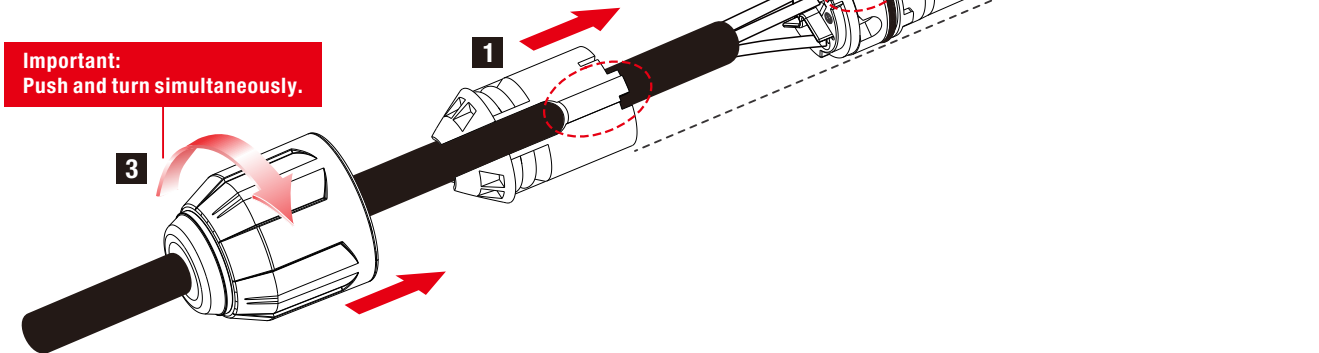

STEP 7 Slide the cable clamp bushing up the cable and tighten it **3**.
 Important: O-ring to hide to achieve IP protection **4**.

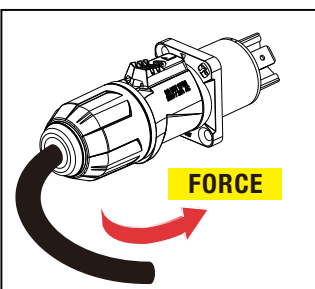
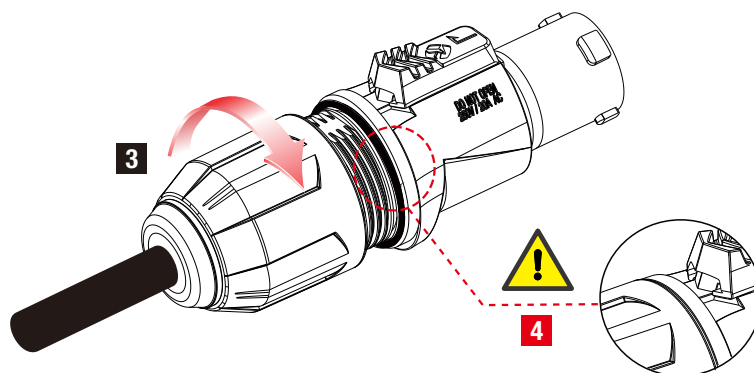

CAUTION

To ensure protection category, do not expose the connection to bending forces (e.g. do not attach loads to the cable, no free-dangling cable windings etc.).

SAFETY WARNING

For safety and certification reasons the connector must be replaced in case of any broken parts or excessive wear and tear.



FINISHED STATUE

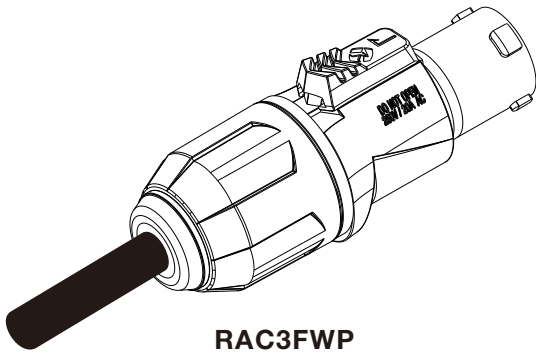

RAC3FWP

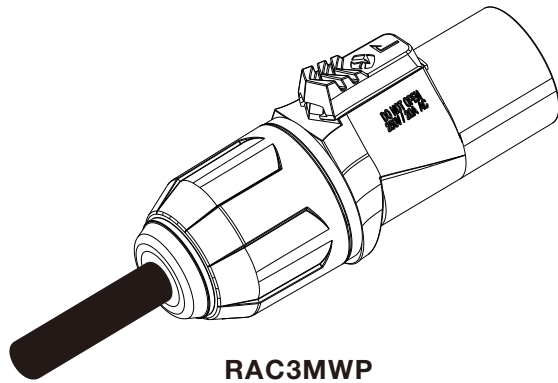

RAC3MWP



www.roxtone.com